

AvK®

DSG 62

Model	DSG 62
Maximum continuous rating at 50Hz (kVA)	1,100
Maximum continuous rating at 60Hz (kVA)	1,320

Specifications	
Voltage Range	400-690
Poles	4
Technology	Bar Wound
AVR	Digital
Voltage sensing	3-Phase
Bearing Arrangement	Double
SAE Adaptors	1, 0, 00
Terminals	6
Material Insulation Class	H
Excitation System	Auxiliary Winding
Ingress Protection	IP23
Temperature monitoring	Winding RTDs
Connection with other machines	Paralleling capability

Optional Features	
Bearing Arrangement	Sleeve Bearings
Ingress Protection	IP23 Air Filters
Ingress Protection	IP44/54/55/56 Totally enclosed
Cooling options	CACA/CACW
Environmental protection	Anti-condensation Heaters

Designed For	
Grid Code Compatible	
Marine Auxiliary	●
Oil & Gas	●
Oil & Gas Auxiliary	●
Combined Heat & Power	●
Critical Protection & UPS	●
Continuous Power & Standby	●

Prime Movers	
Diesel Engine	●
Gas Engine	●



DIMENSIONS

Drawings represent standard design
 All dimensions in millimetres (mm)

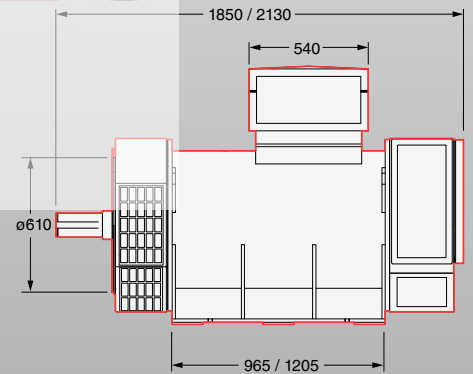
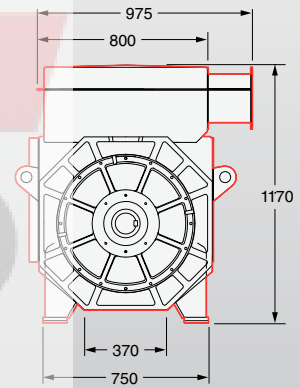

Low Voltage

250 - 1,250 kVA